

# Ace PLCs



## Velocio's Ace PLCs

Ace PLCs are members of the Velocio's groundbreaking series of programmable logic controllers. These PLCs introduce revolutionary new concepts, capabilities, performance and ease of use features to the automation market. They constitute a generational leap over the staid products that have comprised the PLC world for years.

Ace PLCs are the small, stand alone members of the Velocio family. They bring incredible power, in a very small package and at a very low price. Many control system applications require 36 points of IO or less, all located very close to the PLC. For those applications, Aces are the Velocio PLCs that fit the requirements.

Ace PLCs are programmable, using Velocio's vBuilder software. The program development interface between the PC running vBuilder and an Ace is a standard USB communications cable. Through this USB cable, the Ace PLC can be programmed, debugged and deployed.

Ace PLCs interface a variety of inputs and outputs. Certain models have additional communications ports for interfacing HMI's, cellular modems, other PLCs and other devices.

The functionality available for incorporation into your application program is very encompassing and easy to implement.

In addition to the features and interfaces common to most PLCs, Ace PLCs incorporate a number of advanced features. Some of these features include high speed stepper motion control of up to three motors simultaneously, PWM (pulse width modulation), PID control, high speed pulse counter inputs, configurable digital input debounce and custom communications under program control.

The Ace's small size is another key feature. High end automation capabilities are packed into a PLC that fits in a shirt pocket. For those systems with limited availability of space, the Ace can provide a solution.



## Applications

- Machine control
- Process control
- Machine control
- Motion system control
- Automated Test
- Internet of Things
- Integration into standard products

## Features

- Up to 36 Inputs and Outputs
- USB connection to PC and other Host devices
- RS232/RS485 on some models
- Smallest physical footprint of any PLC
- High end software features that are easy to use
- Graphical program development in flow charts or ladder
  - Interactive, graphical debug functionality
  - Software reusability
- Subroutines, PID, motion, statistics & many more
- High speed pulse and direction motion control of up to 3 stepper or servo motors
- PWM capability on all digital outputs

## Benefits

- Enhanced and efficient development process
- Reduced system cost
- Reduced development time
- Improved reliability
- Embeddable within product
- Rapid development and deployment

## Flavors of Ace

There are a growing number of models of Ace PLCs. The units vary with respect to input/output (IO) configuration, number of ports and communications capabilities. They range from the simplest unit, the Ace 11, to higher end units with a great deal of functionality.

	Digital In	Digital Out	Analog In 0-5volt	Analog In 0-10volt	Analog In 0-20mAmp	Analog Out 16 bit	Therm In / Diff Analog In	RS232	RS232 / RS485
Ace 11	6	6							
Ace 1430	6	12						1	
Ace 1450	6	12				2		1	
Ace 22	12	12							
Ace 222v5	12	12	12						
Ace 222v10	12	12		12					
Ace 222c	12	12			12				
Ace 3090v5	6	18	3			4	1		
Ace 3090v10	6	18		3		4	1		
Ace 3090c	6	18			3	4	1		
Ace 5150v5	12	12	3				1		
Ace 5150v10	12	12		3			1		
Ace 5150c	12	12			3		1		
Ace 7096v5	6	12	4			2	4	2	
Ace 7096v10	6	12		4		2	4	2	
Ace 7096c	6	12			4	2	4	2	

## Ace 11

The Ace 11 is the lowest IO count, least expensive member of the family. In addition to basic digital inputs and outputs, it is designed for motion control, PWM outputs and high speed pulse counting.

- 6 Digital Inputs
  - Protected, 3-30VDC
  - High speed pulse counting capability
- 6 Digital Outputs
  - Sinking transistor outputs
  - Step and direction motion control enabled (3 maximum)
  - PWM capable on all outputs
- USB programming port
  - USB port Modbus RTU slave enabled

## Ace 11

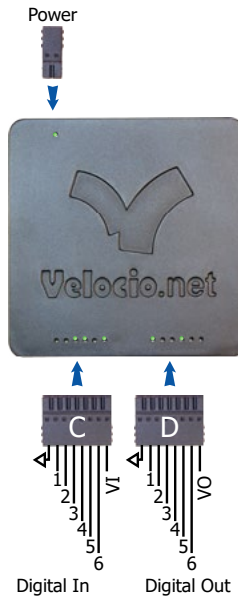

## Ace 22

The Ace 22 provides 12 digital inputs and 12 digital outputs. In addition to basic digital inputs and outputs, it is designed for motion control, PWM outputs and high speed pulse counting.

- 12 Digital Inputs
  - Protected, 3-30VDC
  - High speed pulse counting capability
- 12 Digital Outputs
  - Sinking transistor outputs
  - Step and direction motion control enabled (3 maximum)
  - PWM capable on all outputs
- USB programming port
  - USB port Modbus RTU slave enabled

## Ace 22

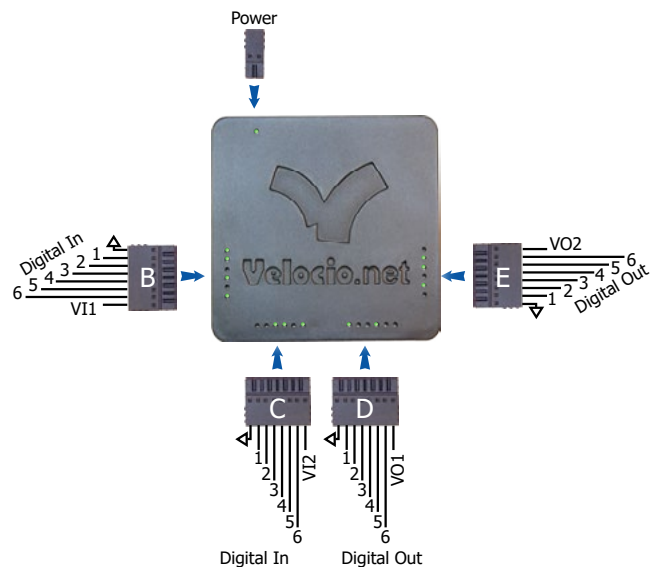

## Ace 222

The Ace 222 includes IO interfaces for 12 digital inputs, 12 digital outputs and 12 analog inputs. The three different models of Ace 222 differ only in the analog signal range they are designed to interface (v5 = 0-5VDC, v10 = 0-10VDC and c = 0-20mA). In addition to basic digital inputs and outputs, it is designed for motion control, PWM outputs and high speed pulse counting.

- 12 Digital Inputs
  - Protected, 3-30VDC
  - High speed pulse counting capability
- 12 Digital Outputs
  - Sinking transistor outputs
  - Step and direction motion control enabled (3 maximum)
  - PWM capable on all outputs
- 12 Analog Inputs, 12 bit resolution
  - Ace 222v5 : 0-5VDC analog inputs
  - Ace 222v10 : 0-10VDC analog inputs
  - Ace 222c : 0-20mA analog inputs (also used for 4-20mA signals)
- USB programming port
  - USB port Modbus RTU slave enabled

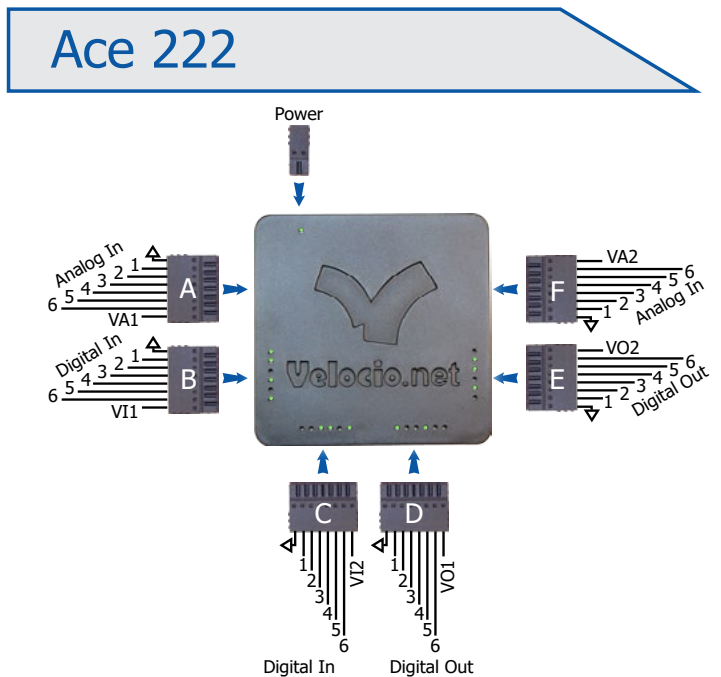

## Ace 1430

The Ace 1430 includes IO interfaces for 6 digital inputs, 12 digital outputs and a serial port that is program configurable as either RS232 or RS485.

- 6 Digital Inputs
  - Protected, 3-30VDC
  - High speed pulse counting capability
- 12 Digital Outputs
  - Sinking transistor outputs
  - Step and direction motion control enabled (3 maximum)
  - PWM capable on all outputs
- Serial port configurable as RS232 or RS485
  - Modbus RTU slave
  - Custom message communications
- USB programming port
  - USB port Modbus RTU slave enabled

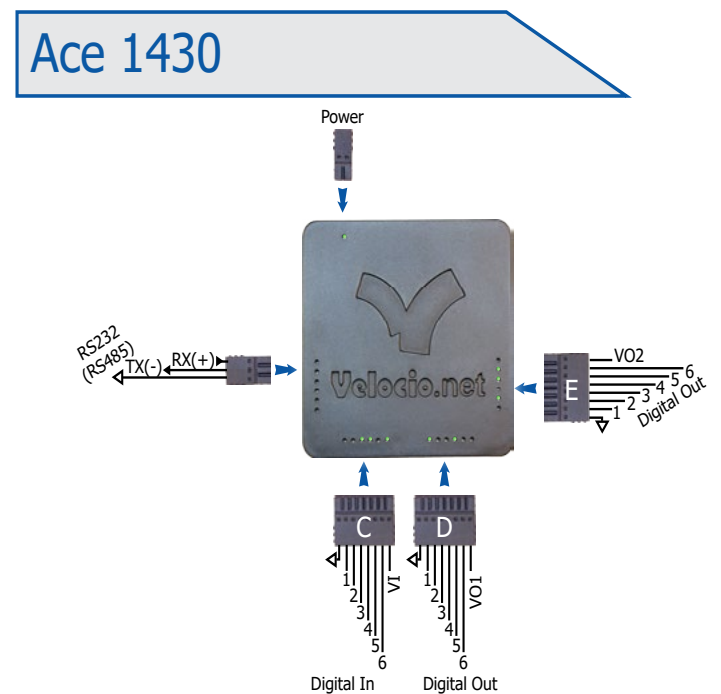

## Ace 1450

The Ace 1450 includes IO interfaces for 6 digital inputs, 12 digital outputs, 2 thermocouple/differential voltage inputs and a serial port that is program configurable as either RS232 or RS485.

- 6 Digital Inputs
  - Protected, 3-30VDC
  - High speed pulse counting capability
- 12 Digital Outputs
  - Sinking transistor outputs
  - Step and direction motion control enabled (3 maximum)
  - PWM capable on all outputs
- 2 thermocouple/differential voltage inputs
  - J, K, T or N thermocouple
  - 16 bit differential voltage input selectable for +/-0.256V, 0.512V, 1,024V, 2.048V, 4.096V and 6.144V ranges
- Serial port configurable as RS232 or RS485
  - Modbus RTU slave
  - Custom message communications
- USB programming port
  - USB port Modbus RTU slave enabled

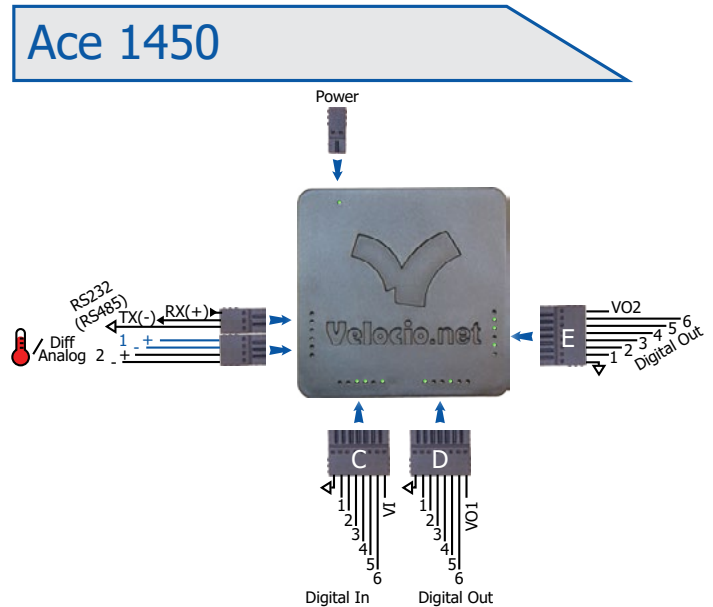

## Ace 3090

The Ace 3090 includes IO interfaces for 6 digital inputs, 18 digital outputs, 3 analog inputs, four thermocouple/differential voltage inputs and an RS232 port. The three different models of Ace 3090 differ only in the analog signal range they are designed to interface (v5 = 0-5VDC, v10 = 0-10VDC and c = 0-20mA).

- 6 Digital Inputs
  - Protected, 3-30VDC
  - High speed pulse counting capability
- 18 Digital Outputs
  - Sinking transistor outputs
  - Step and direction motion control enabled (3 maximum)
  - PWM capable on all outputs
- 3 Analog Inputs, 12 bit resolution
  - Ace 3090v5 : 0-5VDC analog inputs
  - Ace 3090v10 : 0-10VDC analog inputs
  - Ace 3090c : 0-20mA analog inputs (also used for 4-20mA signals)
- 4 thermocouple/low level differential voltage inputs
  - J, K, T or N thermocouple
  - 16 bit differential voltage input selectable for +/-0.256V, 0.512V, 1,024V, 2.048V, 4.096V and 6.144V ranges
- RS232 port
  - Modbus RTU slave
  - Custom message communications
- USB programming port
  - USB port Modbus RTU slave enabled

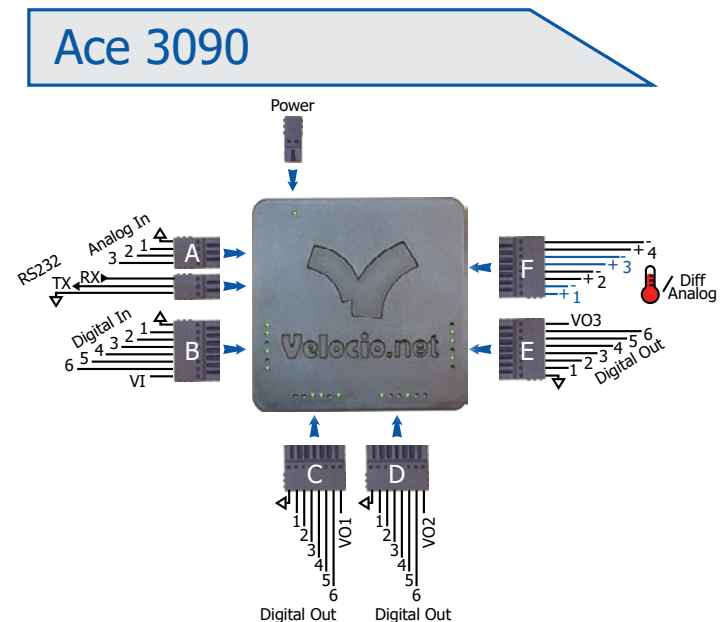

## Ace 5150

The Ace 5150 includes IO interfaces for 12 digital inputs, 12 digital outputs, 3 analog inputs and an RS232 port. The three different models of Ace 5150 differ only in the analog signal range they are designed to interface (v5 = 0-5VDC, v10 = 0-10VDC and c = 0-20mA).

- 12 Digital Inputs
  - Protected, 3-30VDC
  - High speed pulse counting capability
- 12 Digital Outputs
  - Sinking transistor outputs
  - Step and direction motion control enabled (3 maximum)
  - PWM capable on all outputs
- 3 Analog inputs, 12 bit resolution
  - Ace 5150v5 : 0-5VDC analog inputs
  - Ace 5150v10 : 0-10VDC analog inputs
  - Ace 5150c : 0-20mA analog inputs (also used for 4-20mA signals)
- RS232 port
  - Modbus RTU slave
  - Custom message communications
- USB programming port
  - USB port Modbus RTU slave enabled

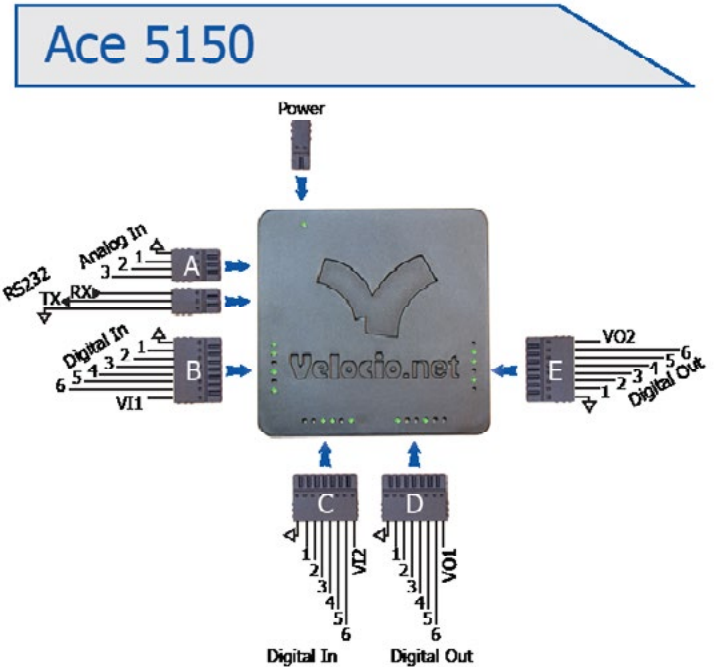

## Ace 7096

The Ace 7096 includes IO interfaces for 6 digital inputs, 12 digital outputs, 4 analog inputs, four thermocouple/differential voltage inputs, two analog outputs and two RS232 ports. The three different models of Ace 7096 differ only in the analog signal range they are designed to interface (v5 = 0-5VDC, v10 = 0-10VDC and c = 0-20mA).

- 6 Digital Inputs
  - Protected, 3-30VDC
  - High speed pulse counting capability
- 12 Digital Outputs
  - Sinking transistor outputs
  - Step and direction motion control enabled (3 maximum)
  - PWM capable on all outputs
- 4 Analog Inputs, 12 bit resolution
  - Ace 7096v5 : 0-5VDC analog inputs
  - Ace 7096v10 : 0-10VDC analog inputs
  - Ace 7096c : 0-20mA analog inputs (also used for 4-20mA signals)
- 6 Analog Outputs
  - 0-5V or 0-10 (selectable using vBuilder)
  - 16 bit resolution
- 4 thermocouple/low level differential voltage inputs
  - J, K, T or N thermocouple
  - 16 bit differential voltage input selectable for +/-0.256V, 0.512V, 1.024V, 2.048V, 4.096V and 6.144V ranges
- 2 RS232 ports
  - Modbus RTU slave
  - Custom message communications
- USB programming port
  - USB port Modbus RTU slave enabled

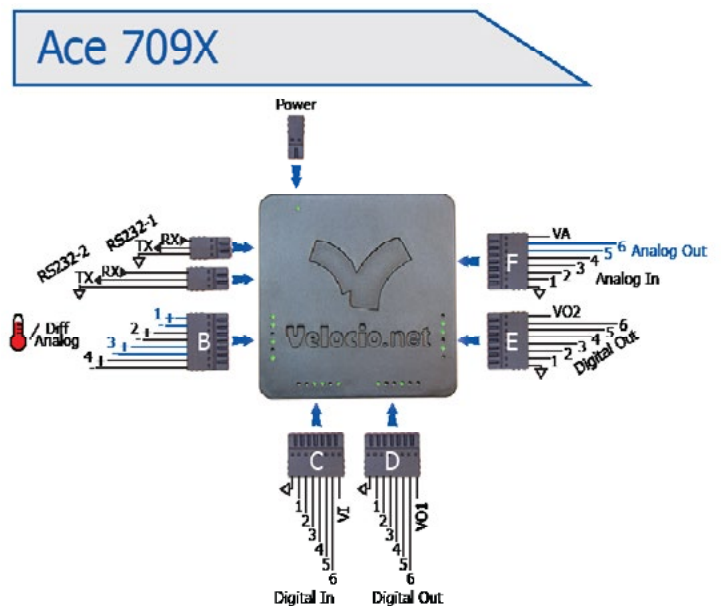

## ◇ Digital Inputs :

All Ace PLCs accept some number of digital inputs. Digital inputs sense binary status, such as on/off, switch open/closed, etc. The Ace PLC can interface any DC voltage signal between 3 and 30VDC. Typical system designs utilize 5V, 12V or 24VDC power supplies, which are all within the Ace's signal range.

Any connection to DC voltage between 3 and 30VDC is sensed as a '1'. Any connection to ground (or voltage below 0.8VDC) or an open connection is sensed as '0'. The ground reference of the signal must be connected to the ground terminal pin next to signal 1, or to the PLC's input power ground.

The figure on the right shows a variety of typical digital input signals that may be connected to Ace digital inputs. Some of the more common ones include :

- Switches (this could be mechanical switches, buttons, limit switches, etc.)
  - Connect one side to positive DC power (from a supply whose ground is connected to the PLC ground)
  - Connect the other side of the switch to the digital input
- Transistor signal
  - For transistor signals that supply voltage when on : connect sensor output to digital input
  - For transistor signals that switch to ground when on : connect to sensor output to digital inputs & if input device does not pull high when inactive, also pull up to positive voltage through a pull up resistor
- Encoder signals
  - Encoders will fall into one of the transistor signal categories listed above
- Logic level signals
  - Make sure that the signal's ground reference is connected to the PLC ground. Connect of input.
  - Make sure that the signal switches high and low.

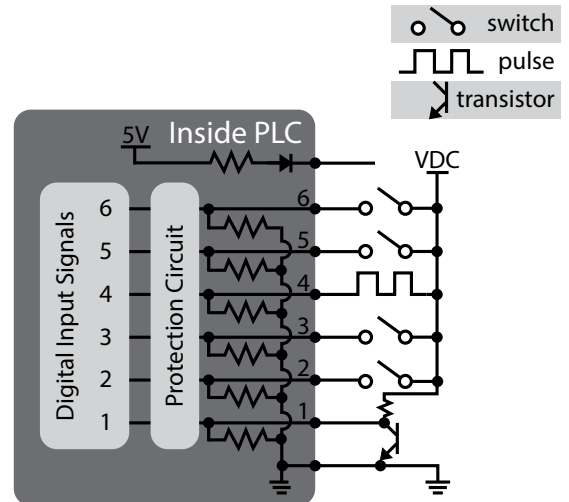

The last pin on each digital input port connector provides a voltage (connected to the 5V power input, through a 10 ohm resistor and a diode) which is used by the Optocouple Input Terminal modules. It can also be used to supply "wetting voltage" to dry contact inputs.

Internally, as part of the protection circuit, each digital input is pulled to ground through a 10K ohm resistor. This pull down resistor ensures that the digital input shows up as inactive when nothing is connected or the connection just sources voltage when it is active.

**Do not connect external power to the voltage pin (pin 8) on the digital input port.**

Input / Output	Name	Signal	Debounce (ms.)
Input bit	InBitB1	B1	0
Input i16	InBitB2	B2	5
Input Float	InBitB3	B3	5
Output bit	InBitB4	B4	0
Output ui16	InBitB5	B5	0
Register	InBitB6	B6	0

Ace digital inputs (and the Ace CPU) are very fast. For a small program, the logic scan and input scan can occur 5 times per millisecond. At this rate, mechanical contact bounce can signal the program that an input is changing rapidly - which can be a problem. To alleviate this situation, vBuilder has an option to allow you to set a debounce time on digital inputs. A debounced digital input will not report a change of state until that change has been continuous for the set debounce time. Note that debounce does not apply to inputs configured as high speed pulse counter inputs.

Using vBuilder, one high speed pulse counter can be configured for basic high speed pulse counting (one digital input), or quadrature pulse counting (two digital inputs). The same signal level requirements apply, as listed above.

For digital inputs that are AC signals, the Ace's digital input ports can be connected to Velocio Optocoupled Input Terminal Block modules. These modules interface 24VAC or 120VAC signals. A cable, supplied with each terminal block module is then connected to the Ace digital input port. The Optocoupler Input Terminal Block modules convert the AC signals to the proper DC levels to the PLC.

## ◇ Digital Outputs :

All Ace PLCs have some number of digital outputs. Ace digital outputs are sinking transistor outputs - which means that they provide the ground connection turn on a load. When switched on under program control, they complete the circuit to turn on any connected DC device up to 30VDC and 300mA.

Each output includes diode snubber protection, for inductive load (solenoids, relays, etc.) protection. The supply voltage, up to 30VDC, which is connected to the load devices, must be connected to the VO terminal pin, next to output 6 of the output port, to enable this protection. All loads connected to a digital output port should be connected to the same DC supply. The load power supply ground must be connected to the ground (next to signal 1) of the output port.

Each output is connected, through a 33K ohm resistor to the VO terminal pin (next to output 6). This acts as a weak pull up. When the output is off (logic state 0), the output will be pulled up to the voltage at the VO terminal. If no power supply connection is made to the VO terminal, the voltage at the VO terminal will come through a 10 ohm resistor and an isolation diode, resulting in a voltage approximately 0.7V below the 5V supply to the PLC. This is enough to allow the PLC outputs to directly interface TTL circuits. If voltage is connected from an external source to the VO terminal, inactive outputs will pull up to the external source voltage.

If AC power, or higher power DC needs to be switched, the Ace's digital output ports can be connected to a Velocio Relay Terminal Block module, through a short standard cable, supplied with the module. With a Relay module, up to 250VAC and 5 Amps can be switched under program control. The cable diagram connection to the PLC digital output port pluggable connector is illustrated in the Relay Terminal Block module documentation.

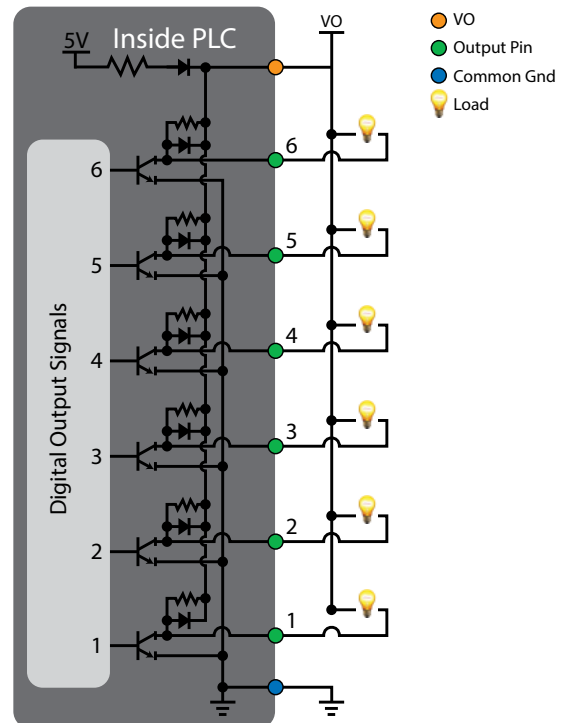

## ◇ Analog Inputs :

Ace PLCs are available with some number of general analog inputs. Ace PLC analog input interfaces are available for either 0-5VDC, 0-10VDC or 0-20mA.

Analog inputs are normally used to connect to transducer outputs. Such transducers measure some physical parameter, such as pressure, temperature, liquid level, position, pH level, or other such continuously variable measurement. The transducer signal output should be connected to a signal input on the Ace analog port and the transducer return or ground reference line must be connected to the PLC ground, next to signal 1 (or otherwise connected to the PLC's ground).

Ace PLCs with current input analog input ports (part number ending in 'c') should be used for analog current signals between 0 and 20 mA. The two most common type of current signals are 4-20 mA and 0-20 mA.

Full range analog signals will convert to a value between 0 and 4095 (12 bits). For 4-20mA inputs, the converted value will be between 820 and 4095. The Scale function in vBuilder can be used to automatically convert the signal value to meaningful data.

For PLCs that have a full 8 position port dedicated to analog inputs, the pin next to the sixth input is connected to the PLC's internal 5V, through a 10 ohm resistor and a diode. This is provided to power a future analog input simulator. It serves no other purpose and should remain unconnected for application use. Analog input ports that do not occupy the full 8 position port do not have this connection.

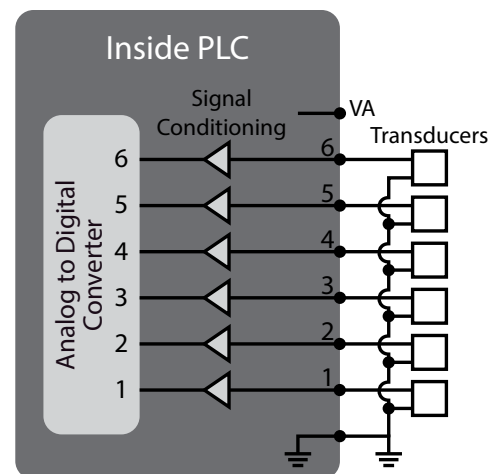



### ◇ Combination Analog Inputs and Analog Outputs

Certain Ace PLCs have a single connector with both analog inputs and outputs. The connections are as shown on the diagram at the right.

The first few signals on the port are analog inputs. They are 12 bit analogs, described in the analog input description. Typically, there are either 3 or 4 analog inputs in a combination port

The last signals on a combination port are analog outputs. For the Ace 7096 these are 16 bit resolution outputs, which can be individually configured, using vBuilder for either 0-5V or 0-10V operation, as shown below.

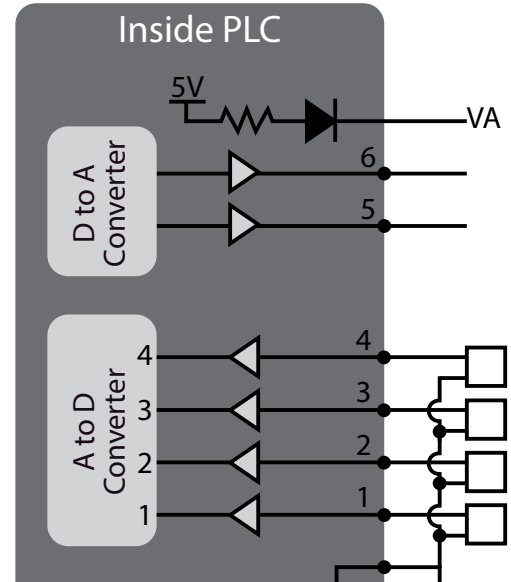
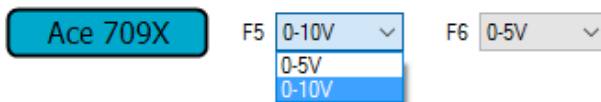

### ◇ Thermocouple/16 bit Differential Low Voltage Analog Inputs

Several Ace PLC's include interfaces that are configurable for either providing thermocouple interfaces or serving as analog inputs for differential analog signals. These signal inputs can be individually configured, in vBuilder, for either thermocouple or differential voltage ranges.

For interfacing to thermocouples, these inputs can be configured for J, K, T or N type thermocouples. Connect each thermocouple to one of the four wire pairs shown in the diagram on the right. The negative (red) wire should be connected to the negative input (indicated by a '-' sign on the diagram). The positive wire should be connected to the positive connection.

Each differential input can also be used to measure low level differential voltage signals. The following ranges are available :

- +/- 0.256V
- +/- 0.512V
- +/- 1.024V
- +/- 2.048V
- +/- 4.096V
- +/- 6.144V

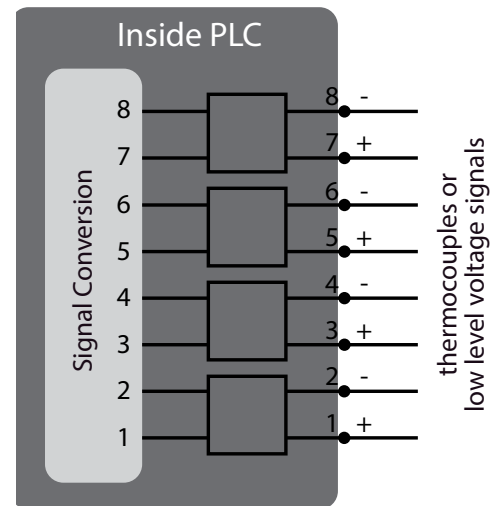

**Thermocouple / Differential Input Setup**

The vBuilder Setup window for the thermocouple/differential analog configuration is shown on the right.

In operation, the signal is converted to a floating point value. That value is either temperature, in degrees Celcius, or volts.

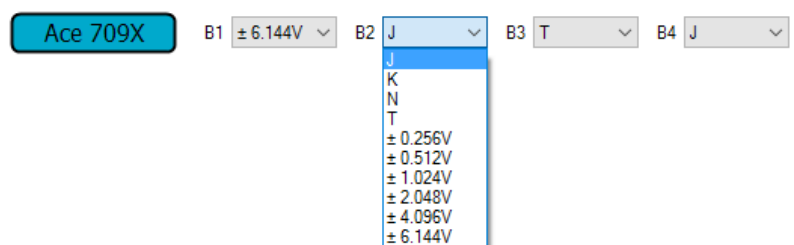

## ◇ RS232 and RS232/485 Ports :

Certain Ace PLCs have RS232 ports or configurable RS232/485 ports. RS232 ports are commonly used for interfacing hardware HMI panels and other devices through Modbus RTU communications. They are also commonly used to interface cellular transceivers for internet of things applications and can be used in Custom communications mode to communicate to any device that has an RS232 port.

RS485 ports are commonly used in multi unit systems and for longer distance communications.

Ace PLC RS232 ports have three pin connectors. The illustration on the right shows the connections.

- Signal ground
- PLC transmit (must be connected to the receive pin of the connected device)
- PLC receive (must be connected to the transmit pin of the connected device)

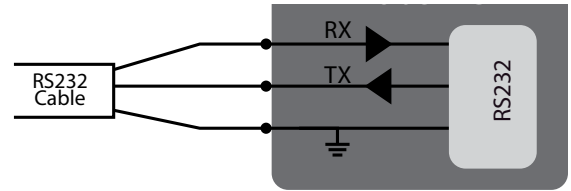

Some Ace PLCs have serial ports that can be configured as either RS232 or RS485. When configured as RS232, the connections are identical to the connections shown for the dedicated RS232 ports. If the port is configured for RS485, the two connections used are the + (or A), on the same pin as the RS232's RX and the - (or B), on the middle pin or RS232's TX pin. The ground can be connected to the cable shield. However, the shield should only be connected at one end of the cable.

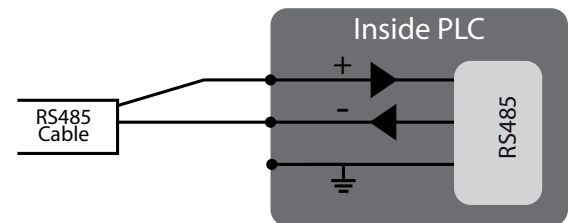

Serial ports can be configured by vBuilder for either Modbus RTU slave or Custom communications operation. Each port can also be configured for a variety of baud rates, the number of stop bits and parity. Serial ports that can be configured for either RS232 or RS485 have another configuration selection for that purpose.

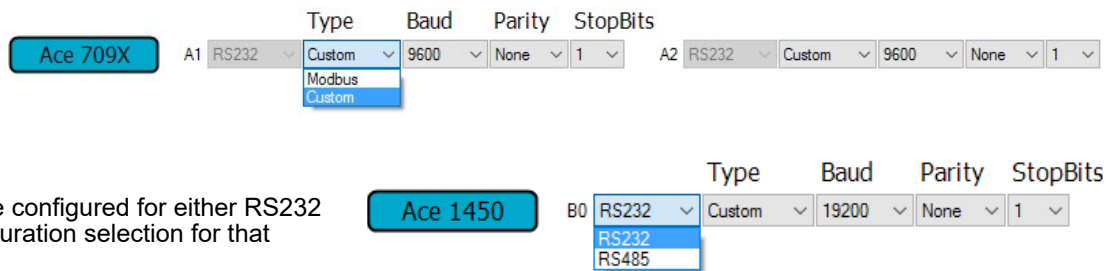

All serial ports support Modbus RTU protocol. The PLCs are slave devices.

The default device address is 1, but can be configured to any desired address via vBuilder.

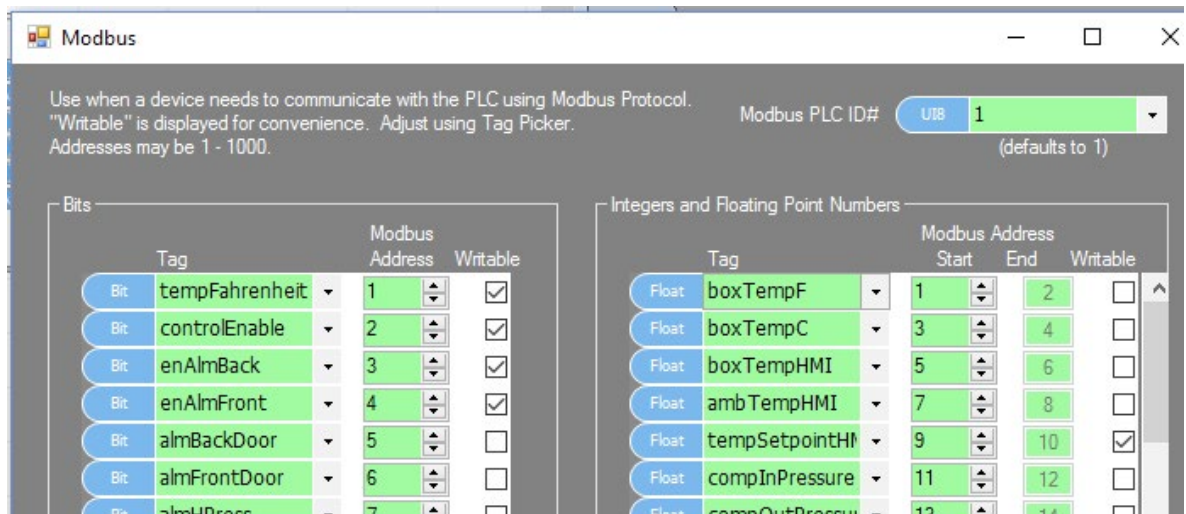

Modbus communications is autonomous and simply requires set up of address mapping, using vBuilder, as shown on the right. Once set up and connected, communications occurs automatically.

When configured for Custom communications, the port will send and receive character (ui8) arrays, under program control, through the use of program blocks like those shown on the right.



## Wire Connections to the Ace Pluggable Terminal Blocks

Ace units come with pluggable terminal blocks, like the one shown on the right. Connect your wires using the larger circular holes on the top row of the orientation shown.



Looking at the connector, in the orientation shown from left to right, the eight wire positions are ground, six signal positions 1 through 6, and either a no connect or voltage connection

You simply need to strip the insulation back about 1/8 inch, insert each wire into the proper round connector hole and push the wire in. It should push in very easily and lock in place. You should not be able to pull the wire back out.



To insert fine stranded wire, insert the blade of a Velocio connector tool (screwdriver) in the rectangular hole directly below the connection hole which you wish to insert your wire. The screwdriver blade should be horizontal (in line with the long dimension of the rectangular hole). This will open the spring capture connection. Simply push your wire in, then remove the blade. If you pull the wire, it should be captured in place and will not come out.



To remove any wire from the connector, use the Velocio screwdriver connector tool. Push the blade into the rectangular slot below the wire to open the spring clamp and release the wire. Gently pull the wire out, then remove the blade.

## Connecting Power

Power to the Ace PLC must be provided via a two position pluggable connector, included with the Ace unit. To connect power, insert the 5VDC and ground connections from a power supply into the plug, as shown in the figure below. When plugged into the PLC's power connector socket, the +5VDC connection is to the right, closest to the corner.



## Shielded Cabling

For applications in which interconnection requires long lengths of wire/cabling in exposed areas, it is highly recommended that shielded cable be used. Long wires act as antennas and have unwanted electrical signals induced onto signal connections. Shielded cable (grounded at one end) will shield the signal wires from unwanted and potentially dangerous electromagnetic interference.

## Mounting Options

Each Velocio PLC comes with a double sided adhesive pad for attaching to painted metals, plastics or glass. Using this method of attachment allows you to install the PLC in very tight and unusual environments as well as place them in typical electrical control panels. The adhesive is very strong and will provide a solid permanent attachment, unless extreme pressure is applied to break the seal.

Alternatively, Velocio PLCs are designed to add an optional vMount DIN rail mounting adapter. The vMount adapter snaps onto the bottom side of the PLC. It can then be snapped onto a standard 35mm DIN rail, or can slide onto a pair of properly spaced screws.

DIN rail mounting is illustrated on the right. The necessary hole pattern for screw mounting is shown below.

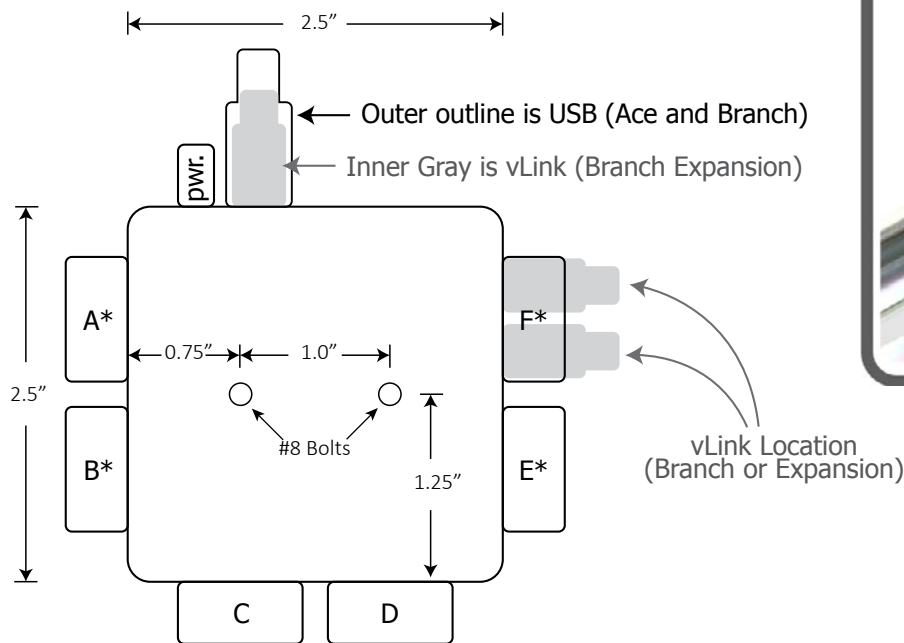



# Specifications :

## Hardware Specifications

Power :

- Voltage 4.75 - 5.5VDC
- current 300mA maximum  
< 100mA typical

Digital Inputs :

- Type : DC voltage input
- Input range : 3 to 30 VDC
- Internal pull down to ground : 10K ohms
- Input low (or 0) signal : 0 to 0.8V, or open connection
- Input high (or 1) signal : 2.5 to 30VDC
- Pulse counter input frequency :
  - up to 100 KHz (typical)
  - up to 250 KHz (maximum)
- Program selectable debounce : 0 to 255 milliseconds

Digital Outputs :

- Type : Sinking transistor
- Voltage range : 3 to 30VDC
- Current : 300 mA maximum
- Motion output pulse frequency
  - 0 to 250 KHz (maximum)
- PWM resolution : 1 microsecond
- Off state pull up resistance to VO : 33Kohms

Analog Inputs :

- Type :
  - v5 = 0 to 5VDC:
  - v10 = 0 to 10VDC
  - c = 0 to 20 mA
- resolution : 12 bit

Analog Outputs :

- Types : selectable ; 0-5V, 0-10V
- resolution : 16 bit

Thermocouple/Differential Voltage Inputs :

- Types : selectable ; J, K, T and N or -
  - +/- 0.256V
  - +/- 0.512V
  - +/- 1.024V
  - +/- 2.048V
  - +/- 4.096V
  - +/- 6.144V
- Output value : floating point value in degrees C or V

## Communications :

Upstream : USB Device  
mini USB connector

RS232 : 3 wire (TX, RX and ground)

RS485 : 2 wire

- baud rates selectable ;
  - 9600 baud
  - 19200 baud
  - 38400 baud
  - 57600 baud
- parity selectable
- stop bits selectable

## Physical Dimensions :

2.5"H x 2.5"W x 0.5" deep

## Environmental

Operating temperature : -40 to +85C  
Humidity : 0 to 95% (non-condensing)

## Software Specifications

Application Program Limits (in Ace PLC)

Program Memory :	34K Words
Maximum rungs or function blocks	4K
Maximum # Subroutines	68
Maximum Tagnames	950
Main Program data memory	
Bits	2,048
unsigned 8 bit integers	512
unsigned 16 bit integers	512
signed 16 bit integers	512
signed 32 bit integers	256
floating point numbers	256
Object Memory (used for subroutine data)	
object words	4,096
object bits	up to 65,536
object 8 Off integers	up to 8,192
object signed 16 bit	up to 4,096
object unsigned 16 bit	up to 4,096
object signed 32 bit	up to 2,048
object floating point	up to 2,048
Maximum # objects	292
Maximum # PWM outputs	all digital outputs
Maximum # of Stepper Motion Controls :	3
Maximum Stepper Motion speed (Hz)	250,000

## Terminal Block Connections

Terminal type Socket connectors and  
Spring cage capture plug

Terminal spacing : 2.50 mm

Wire AWG 20 to 26 AWG\*

\* best wire fit is with 22 or 24 AWG