



Leadshine

Datasheet of the Easy Servo Drive *ES-D508*



20-45VDC, 8.0A Peak, Closed-loop, No Tuning

ZETEK®

Features

- Step and direction control
- Closed position loop for no loss of movement synchronization
- Operating voltage: 20-45 VDC
- Load based output current of 0.5 - 8.0 A
- High torque at starting and low speed
- No torque reservation
- High stiffness at standstill
- Significantly reduced motor heating
- Smooth motor movement and extra low motor noise
- Quick response, no delay and zero settling time
- No loss of steps; no hunting; no overshooting
- Plug-and-play and no tuning

Descriptions

ES-D508 is one of the models in Leadshine ES-D series easy servo drives which can take 20-45 VDC operating voltage and output 0.5 - 8.0 A continuous load-based current. It is capable of driving NEMA 17, 23, 24 and 34 (1-2 stacks) easy servo motors (stepper motors with encoders) with the position loop closed in real time.

Based on latest DSP technology and adopting Leadshine's advanced control algorithm, ES-D508 easy servo drive applies servo control on easy servo motors. When adopted with an easy servo motor, it combines features of both open loop steppers & brushless servo systems, and offers many unique advanced features for excellent motion control system performance.

When an ES-D508 easy servo drive is implemented with a Leadshine ES-M series easy servo motor, there is No Configuration Needed for almost all applications. The factory setting of the resolution is 4000 pulses per revolution (equal to 20 microstep in 2-phase stepper systems). With Leadshine configuration software, ProTuner, an advanced user can also set custom settings of resolution, current & position loop parameters, idle current percentage, etc.

Applications

With many unique advanced features, Leadshine ES-D508 easy servo systems are ideal for many industries to upgrade stepper performance or replace brushless servo systems in many applications.

Leadshine OEM clients have successfully implemented ES-D508 driven easy servo systems in applications such as desktop CNC routers, small CNC mills, laser cutters / engravers, dental mills, electronic assembly & inspection equipments, labeling equipments, pick & place machines, X-Y tables, scientific instruments.

Specifications

Electrical Specifications

Parameter	Min	Typical	Max	Unit
Input Voltage	20	36	50	VDC
Output Current	0.5	-	8.0(Peak)	A
Pulse Input Frequency	0	-	200	kHz
Logic Signal Current	7	10	16	mA
Isolation Resistance	500	-	-	MΩ

Operating Environment

Cooling	Natural Cooling or Forced cooling	
Operating Environment	Environment	Avoid dust, oil fog and corrosive gases
	Ambient Temperature	0°C — 50°C (32°F — 122°F)
	Humidity	40%RH — 90%RH
	Operating Temperature (Heat Sink)	70°C (158°F) Max
Storage Temperature	-20°C — 65°C (-4°F — 149°F)	
Weight	280 g (9.9 oz)	

Mechanical Specifications

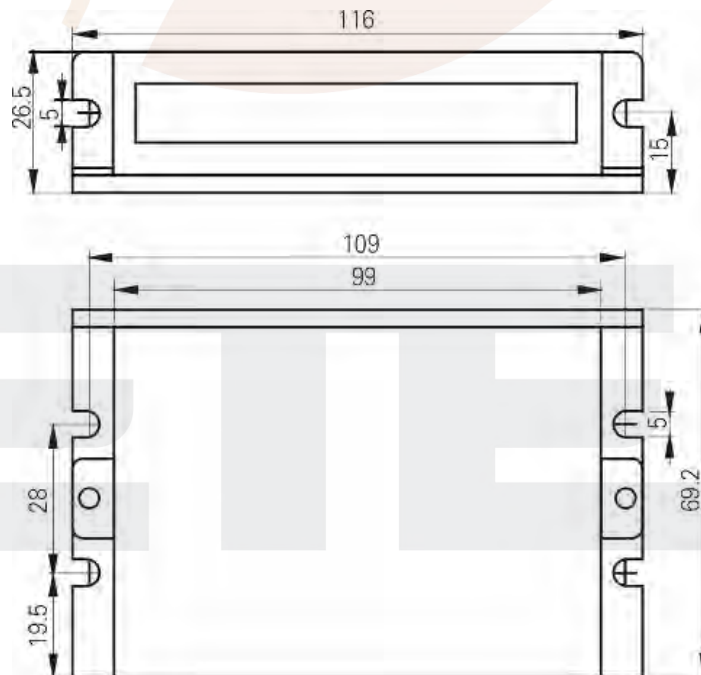

Protection Indications

The green indicator turns on when power-up. When drive protection is activated, the red LED blinks periodically to indicate the errors.

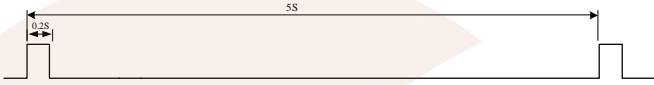
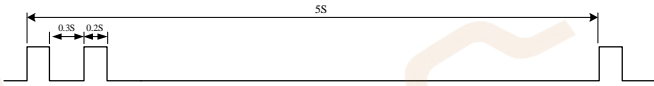
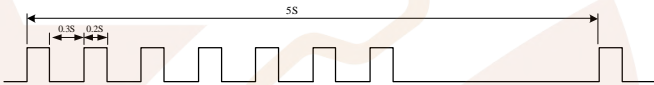
Priority	Time(s) of Blink	Sequence wave of RED LED	Description
1st	1		Over-current protection
2nd	2		Over-voltage protection
3rd	7		Position Following Error

Connectors and Pin Assignment

The ES-D508 has three connectors, connector for control signals connections, connector for encoder feedback and connector for power and motor connections.

Control Signal Connector - Screw Terminal			
Pin	Name	I/O	Description
1	PUL+	I	<u>Pulse Signal</u> : In single pulse (pulse/direction) mode, this input represents pulse signal, each rising or falling edge active (software configurable, see easy servo software operational manual for more details); In double pulse mode (software configurable), this input represents clockwise (CW) pulse, active both at high level and low level. 4-5V when PUL-HIGH, 0-0.5V when PUL-LOW. For reliable response, pulse width should be longer than 2.5 μ s. Series connect resistors for current-limiting when +12V or +24V used. The same as DIR and ENA signals.
2	PUL-	I	
3	DIR+	I	<u>Direction Signal</u> : In single-pulse mode, this signal has low/high voltage levels, representing two directions of motor rotation. In double-pulse mode (software configurable), this signal is counter-clock (CCW) pulse, active both at high level and low level. For reliable motion response, DIR signal should be ahead of PUL signal by 5 μ s at least. 4-5V when DIR-HIGH, 0-0.5V when DIR-LOW. Toggle DIP switch SW1 to reverse motion direction.
4	DIR-	I	
5	ENA+	I	<u>Enable Signal</u> : This signal is used for enabling/disabling the driver. In default, high level (NPN control signal) for enabling the driver and low level for disabling the driver. Usually left UNCONNECTED (ENABLED). Please note that PNP and Differential control signals are on the contrary, namely low level for enabling. The active level of ENA signal is software configurable.
6	ENA-	I	

Connectors and Pin Assignment (Continued)

Control Signal Connector - Screw Terminal			
Pin	Name	I/O	Description
7	FAULT+	O	Fault Signal: OC output signal, active when one of the following protection is activated: over-voltage, over current, short circuit and position following error. This port can sink or source 20mA current at 24V. In default, the resistance between FAULT+ and FAULT- is low impedance in normal operation and become high when the ES-D508 goes into error. The active level of alarm signal is software configurable. See easy servo software operational manual for more details.
8	FAULT-	O	

Encoder Feedback Connector – HDD15 Female			
Pin	Name	I/O	Description
1	EA+	I	Encoder channel A+ input
2	EB+	I	Encoder channel B+ input
3	EGD	GND	Signal ground
4	NC	I	Not Connected, Reserved for future use.
5	NC	I	Not Connected, Reserved for future use.
6	FG	-	Ground terminal for shielded
7	NC	I	Not Connected, Reserved for future use.
8	NC	I	Not Connected, Reserved for future use.
9	NC	I	Not Connected, Reserved for future use.
10	NC	-	Not Connected
11	EA-	I	Encoder channel A- input
12	EB-	I	Encoder channel B- input
13	VCC	O	+5V @ 100 mA max.
14	NC	-	Not Connected
15	NC	-	Not Connected

Power and Motor Connector- Screw Terminal			
Pin	Name	I/O	Description
1	U	O	Motor Phase U
2	V	O	Motor Phase V
3	W	O	Motor Phase W
4	+Vdc	I	Power Supply Input (Positive), 20-45VDC recommended, leaving rooms for voltage fluctuation and back-EMF.
5	GND	GND	Power Ground (Negative)

RS232 Communication Port

It is used to configure the peak current, microstep, active level, current loop parameters and anti-resonance parameters.

RS232 Communication Port – RJ11

Pin	Name	I/O	Description
1	NC	-	Not connected.
2	+5V	O	+5V power output.
3	TxD	O	RS232 transmit.
4	GND	GND	Ground.
5	RxD	I	RS232 receive.
6	NC	-	Not connected.

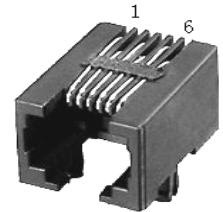

DIP Switches

	Function	On	Off
SW1	Default Direction ^{Note}	CW (clock-wise)	CCW (counter-clock-wise)
SW2	Self-test	Self-test is active	Self-test is close

Note: the actual direction is related to the DIR level. You can toggle SW1 to change it once.

Current Control

The motor current will be adjusted automatically regarding to the load or the stator-rotor relationship. However, the user can also configure the current in the tuning software. The configurable parameters include close-loop current, holding current, encoder resolution, micro step and etc. There are also PID parameters for the current loop, and they have been tuned for Leadshine's matching motors so the user does not need to tune them.

Easy Servo Motors

The ES-D508 can work with the following Leadshine easy servo motors:

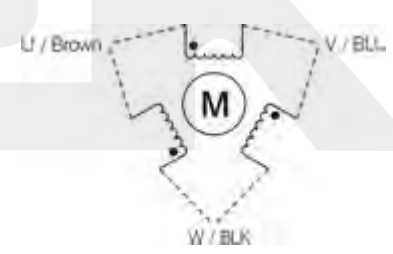
	ES-M32309	ES-M32320	Wiring Diagram
Step Angle (Degree)	1.2	1.2	
Holding Torque (N.m)	0.9	2.0	
Phase Current (A)	5.8	5.8	
Phase Resistance (Ohm)	0.37	0.62	
Phase Inductance (mH)	0.92	1.85	
Inertia (g.cm ²)	300	500	
Weight (Kg)	0.7	1.3	
Encoder (lines / Rev.)	1000	1000	

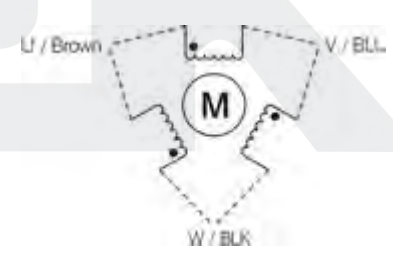

Motor Encoder Cable Pin-Out

ES-M32309, ES-M32320

Pin	Name	Wire Color	I/O	Description
1	EA+	Black	O	Channel A+ output
2	VCC	Red	I	+5V power input
3	GND	White	GND	Ground
11	EB+	Yellow	O	Channel B+ output
12	EB-	Green	O	Channel B- output
13	EA-	Blue	O	Channel A- output

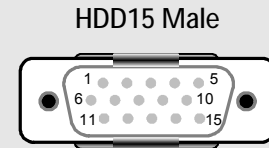

Motor Encoder Extension Cable

CABLEG-BMXMX

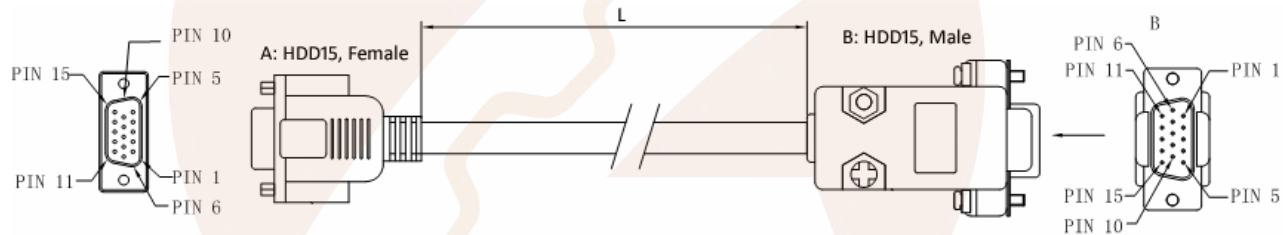

Pin Assignments

A: HDD15 Female	Wire Color	B: HDD15 Male	Name	Description
Pin		Pin		
1	Black	1	EA+	Channel A+
2	Red	13	VCC	+5V power input
3	White	3	GND	+5V GND
11	Yellow	2	EB+	Channel B+
12	Green	12	EB-	Channel B-
13	Blue	11	EA-	Channel A-

Cable Length

Part Number	L	Matching Motor
CABLEG-BM3M0	3.0m	ES-M32309, ES-M32320
CABLEG-BM8M0	8.0m	
CABLEG-BM10M0	10.0m	
CABLEG-BM12M0	12.0m	

Note: The encoder extension cable must be connected between the ES-M323 motor and the ES-D508. You can not connect the motor's encoder cable to the ES-D508 directly.

Motor Power Extension Cable

CABLEH-RZXXM

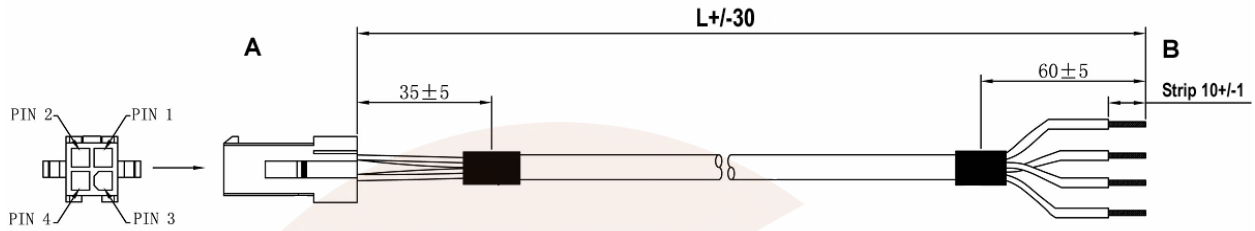

Pin Assignments

A	B	Name	Description
Pin	Wire Color		
1	Blue	V	Motor Phase V
2	Red	U	Motor Phase U
3	Black	W	Motor Phase W
4	Yellow / Green	NC	No connection

Cable Length

Part Number	L	Matching Motor
CABLEH-RZ3M0	3.0m	ES-M32309, ES-M32320
CABLEH-RZ5M0	5.0m	
CABLEH-RZ10M0	10.0m	

Typical Connections

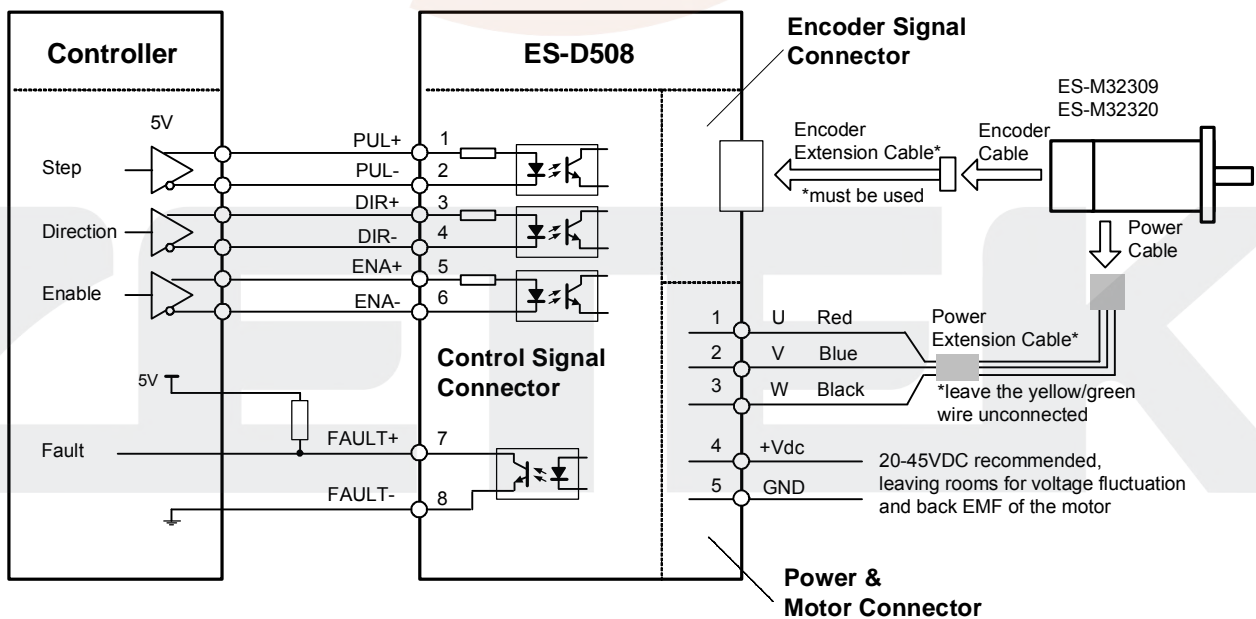

Connections to controller of differential output

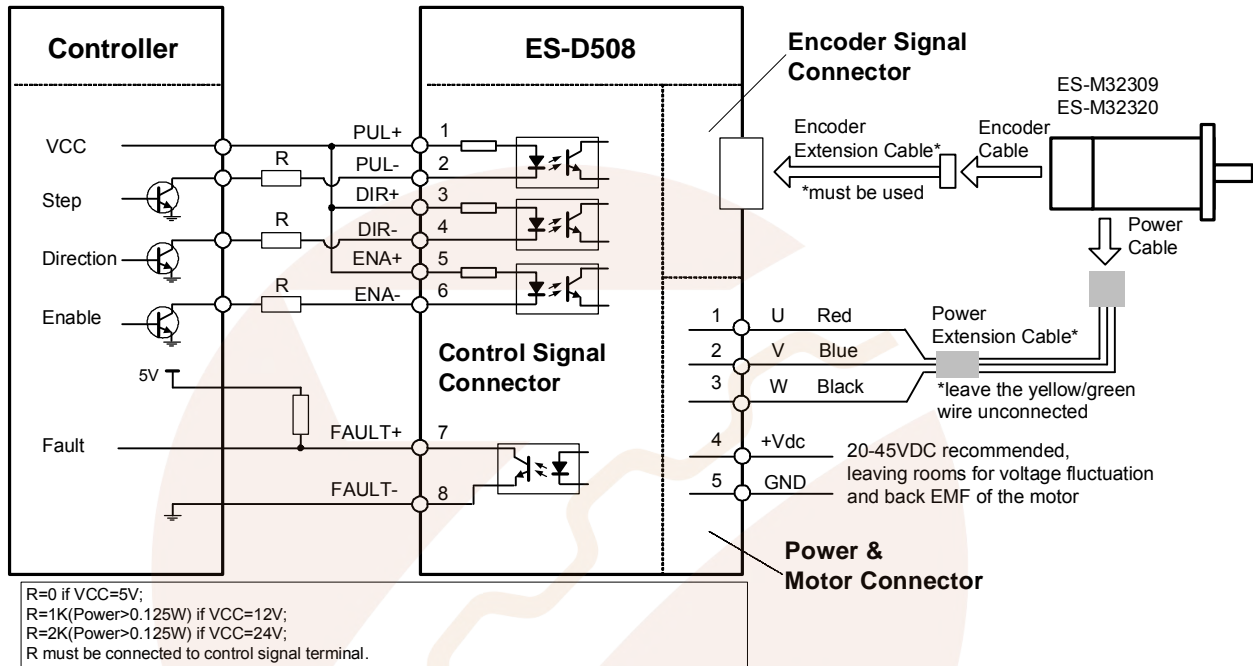
Typical Connections (Continued)

Connections to controller of sinking output

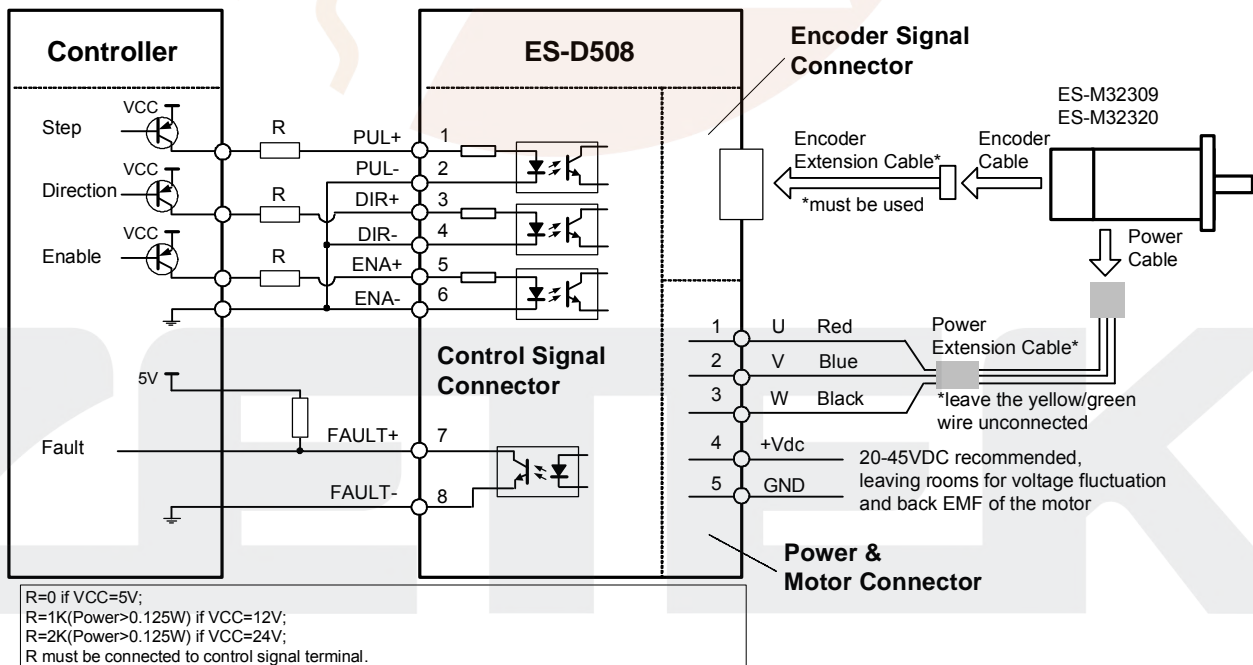

Connections to controller of sourcing output